

PRORIL

50Hz

GOMAX Series, these non-clog pumps employ a single-channel enclosed impeller to efficiently and reliably transfer 76mm diameter solids without clogging. GOMAX series pumps are suitable for commercial and industrial wastewater applications.

Sewage Pump

GOMAX 4110/6110

Single Channel Pump

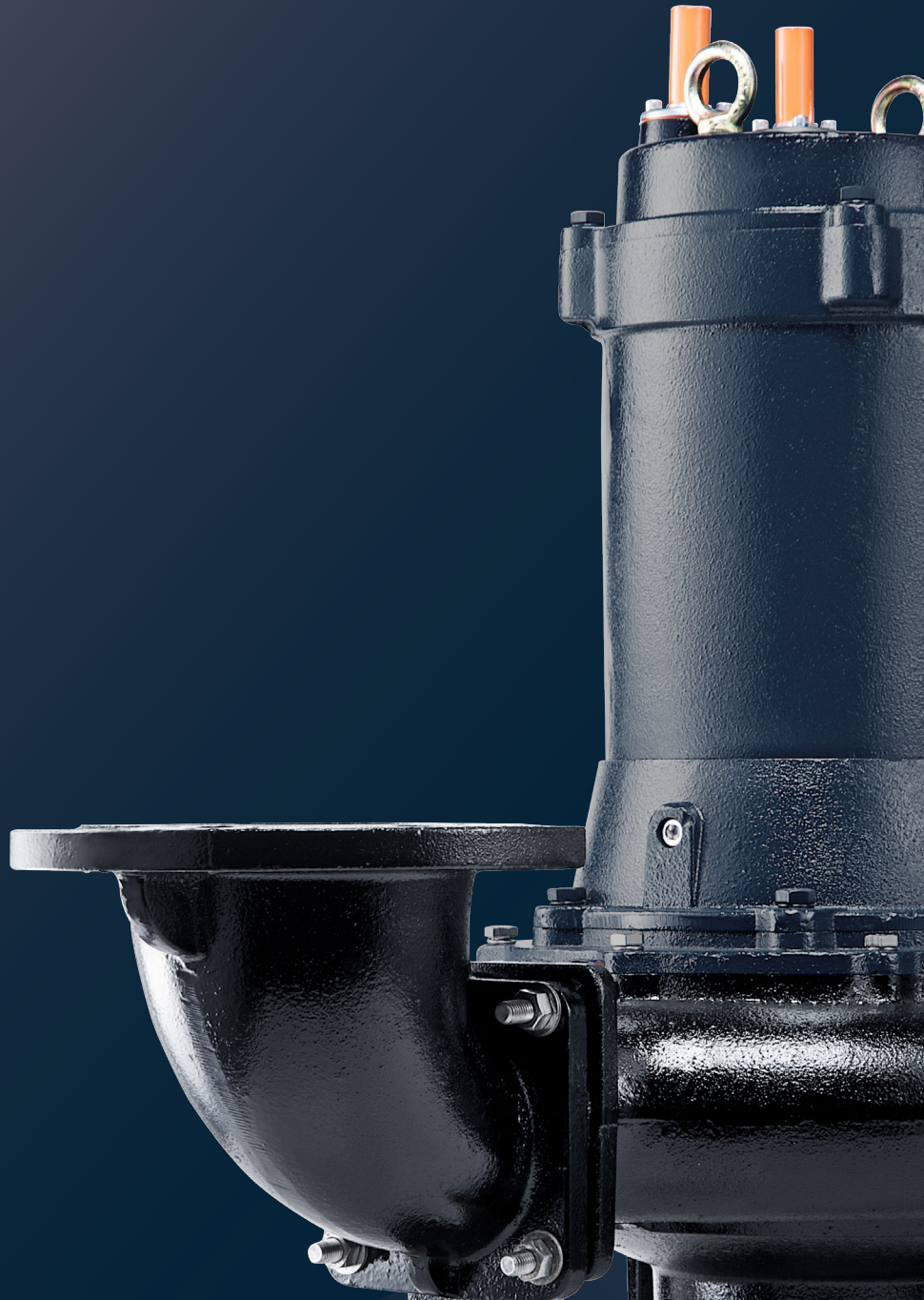

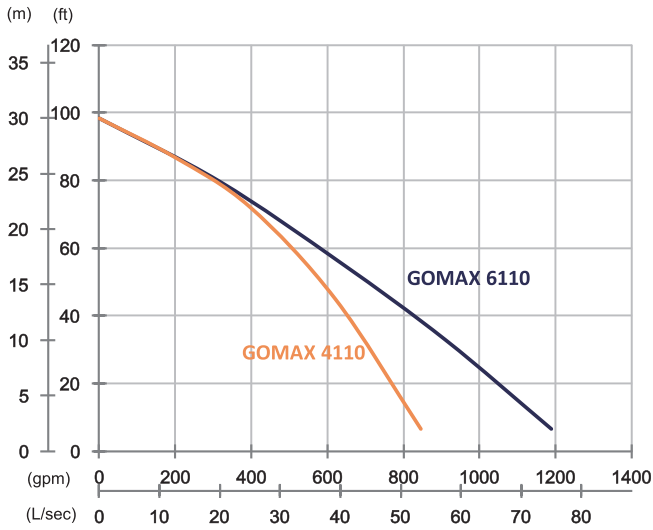

	GOMAX 4110	GOMAX 6110
OUTPUT	11 kW (15 HP)	11 kW (15 HP)
OUTLET	4" (100 mm)	6" (150 mm)
SOLID PASSAGE	76 mm	76 mm
Weight	167 kg	175 kg
HEAD	Rated: 22 m Max: 30 m	Rated: 17 m Max: 30 m
FLOW	Rated: 25 L/s Max: 53.3 L/s	Rated: 40 L/s Max: 75 L/s

Pump Type		Electric Submersible Pumps	
Motor	Phase	3-Phase	
	Type	Induction Motor	
	Poles	4 Pole (1450 rpm)	
	Insulation	Class F	
	Protector		Star-Delta · Miniature Thermal Sensors
			D.O.L. · Circle Thermal Protector
Starter		Star-Delta, D.O.L.	
Lubricant		Food Grade (ISO VG32)	
Specs.	Impeller Type	Single Channel	
	Shaft Seal		Double Mechanical Seal
			Silicon Carbide VS Ceramic/Carbon
	Bearings		C3 Shielded ball bearings
	Cable		H07RN-F
		10 m or longer upon request	
Materials	Pump Casing	Gray Iron	
	Impeller	Gray Iron	
	Motor Frame	Gray Iron	
	Motor Shaft	Stainless Steel	
	Mouth Ring	Copper Alloy	
Max. Liquid Temperature		40°C (104°F)	
Max. Submersion Depth		20 m (66 ft)	
pH Range		pH 5 - pH 8	
Guide Rail		GRN-04	

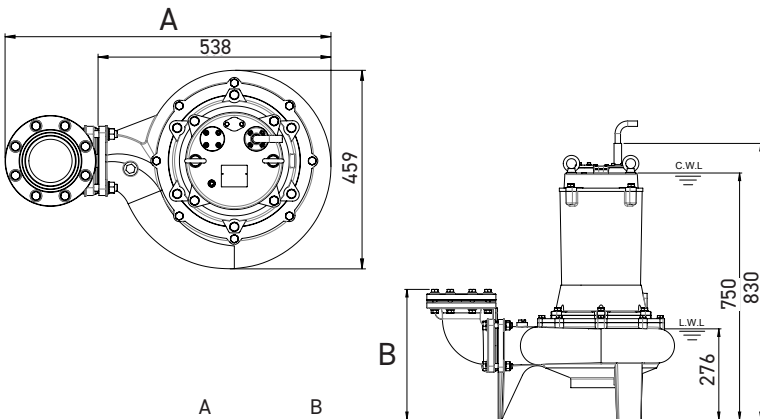

	A	B
GOMAX 4110	753	379
GOMAX 6110	813	452

unit : mm
C.W.L : Continuous running water level
L.W.L : Lowest running water level